

# HP Baghouse Collectors

## Product Overview

The HP product line is a rectangular pulse-jet baghouse. The three versions, HPH, HPT, and HPW, are used for the collection of airborne dust and particulate. They provide highly efficient, continuous, on-line dust collection.

The HP collectors feature a high inlet design, unique oval bags and cages, and a unique bag cleaning system. The standard bag length is 8 feet (2.44 m). The HP is typically sized for applications between 8,000 and 30,000 cfm (13,592 and 50,970 m<sup>3</sup>/h), with the HPH sized for specialized applications between 3,000 and 11,000 cfm (5,097 and 18,689 m<sup>3</sup>/h).

The HPH is a low-profile collector with horizontal bag and cage placement. The HPT is a taller collector with vertical bags and cages. The HPW also has vertical bags and cages, but with a walk-in top section. The bags are serviced from the clean air side of all three models of the HP baghouse.

The HP was designed in 1984 by Carter-Day (purchased by the Donaldson Company in 1987) and has the capability to operate at air-to-cloth ratios up to twice those of conventional pulse-jet units, with no loss in efficiency or increase in pressure drop across the bags. This design provides the customer with a compact collector that is less expensive to purchase and less costly to maintain.

## Operation Explanation

**Normal Operation:** During normal operation dust-laden air enters the high HP inlet section next to the bags. The airflow must turn 90° to pass through the bag section. The energy loss from turning and velocity reduction in the inlet section cause the heavier dust particles to drop directly into the hopper below. A standard inlet baffle helps evenly distribute the dust-laden air around the bags. The dust is collected on the outside surface of each bag. The clean air passes through the bags into the clean air plenum, where it is discharged through the clean air outlet.

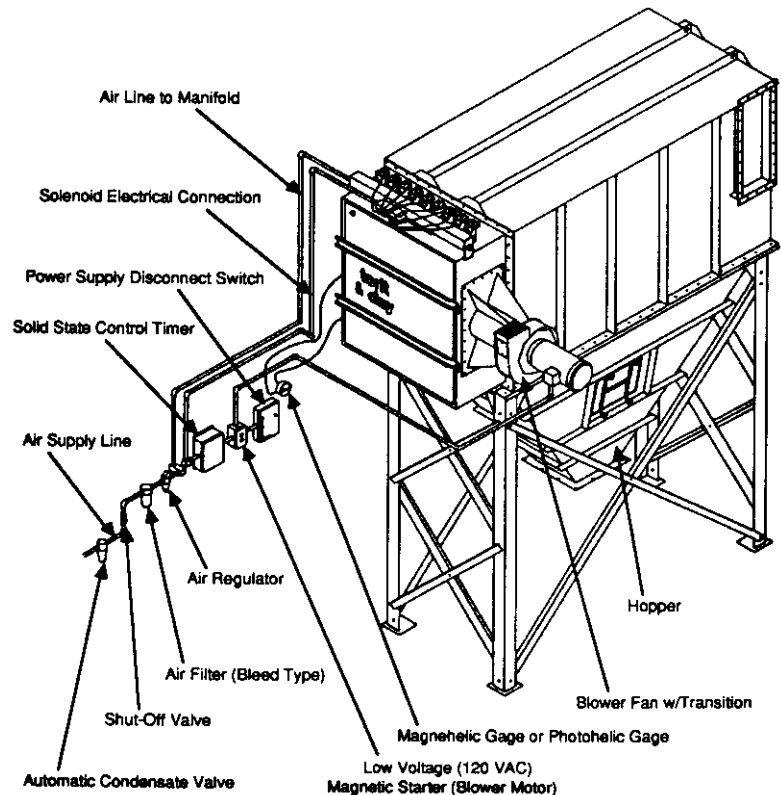

**Filter Cleaning:** Bags (filter tubes) are cleaned automatically and sequentially. Only one row of bags is cleaned per pulse. During the bag cleaning purge, the solid-state timer energizes a solenoid valve, causing the corresponding diaphragm valve to send a pulse of compressed air out into the blowpipe. The blowpipe is equipped with two (2) high pressure nozzles centered over each oval-shaped bag. The high pressure pulse enters the inside of the bag, forcing air through the bag. The collected contaminants are blown from the outside surface of the bags. The dust falls into the hopper where it is discharged by a screw conveyor, rotary valves, or dropped directly into storage drums.

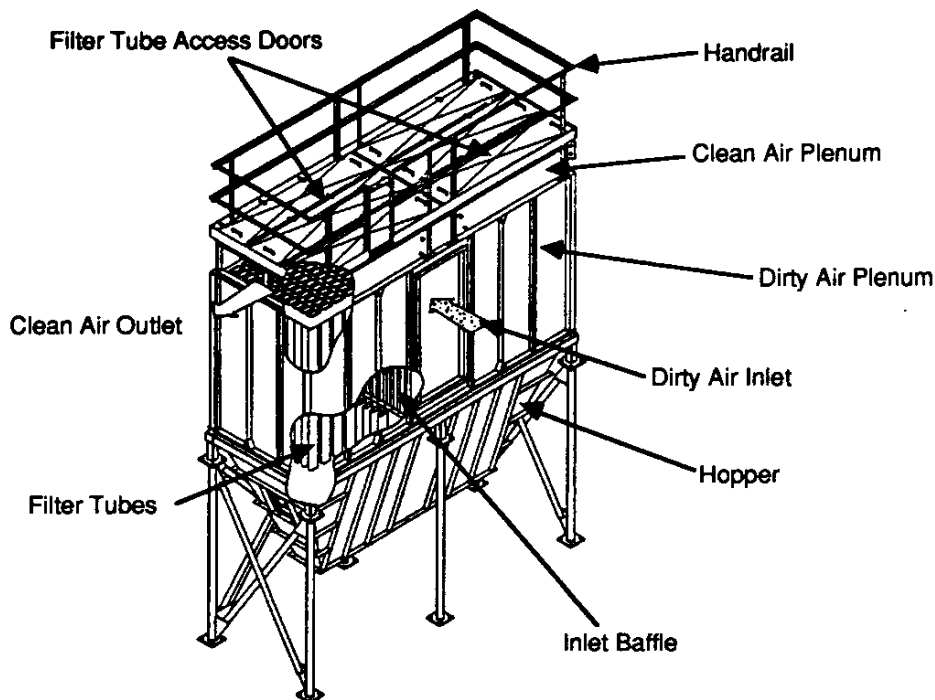

## Application Summary

The HP is a competitively priced alternative to standard pulse-jet units for airflows between 8,000 and 30,000 cfm (13,592 and 50,970 m<sup>3</sup>/h). Lower airflow applications where headroom is limited may present opportunities for the HPH horizontal bag unit.

While the HP can be used in any application for which a baghouse is suitable, it loses its sizing (high air-to-media ratio) advantage on fine, near mono-sized, spherical non-agglomerative dusts.

## Sizing and Selecting

The sizing of HP collectors is based on the air-to-media ratio for the dust and the operating conditions of the application. For the maximum recommended air-to-media ratio, use the "Ruler of Dust Collection" slide rule available through your regional sales office or Applications Engineering

To determine the size of collector, determine the filter area required by using this formula:  
Required filter area = CFM ÷ air-to-media ratio. Once the required filter area is known, a unit

can be selected.

## Features/Advantages/Benefits

| Features  | Advantages  | Benefits   |
|---|---|--|
| <p><b>Heavy-duty construction:</b></p> <ul style="list-style-type: none"> <li>• Minimum 12-gauge housing</li> <li>• Tubesheet is reinforced 1/4" (6 mm) plate steel</li> <li>• Special bag cages using 9-gauge galvanized wire</li> <li>• Bolt-in 10-gauge baffle section</li> </ul>  | <ul style="list-style-type: none"> <li>• Ensures flat, rigid support for bags</li> <li>• In-house quality control</li> </ul>  | <ul style="list-style-type: none"> <li>• Less wear on bags</li> <li>• Protects bags from particle abrasion</li> </ul>  |
| <p><b>Unique inlet design:</b></p> <ul style="list-style-type: none"> <li>• Inlet runs parallel to bags along the full length of the unit's side</li> </ul>   | <ul style="list-style-type: none"> <li>• Provides settling area for large particles and allows a "side draft" to the bags</li> <li>• Promotes better dust settling (less re-entrainment) during pulsing by eliminating upward air velocities</li> </ul>   | <ul style="list-style-type: none"> <li>• Allows unit to operate at high air-to-media ratios</li> </ul>   |
| <p><b>Unique bag design and bag cage system:</b></p> <ul style="list-style-type: none"> <li>• Oval bag</li> <li>• O-Ring sewn into the top of the bag is larger than the tubesheet opening</li> <li>• Method of securing bag frame to tubesheet is positive. O-Ring is compressed against the tubesheet by the frame at the top of the bag cage. The frame is secured by two (2) bolts.</li> <li>• Self-piloting, captive-style bolts on frame provide grounding of the bag cage</li> </ul> | <ul style="list-style-type: none"> <li>• Oval bag design cleans better than round bag design because of more snap in the flat side of the oval</li> <li>• Airtight seal between the bags and tubesheet</li> <li>• Eliminates the need for ground wires in the bags and grounding bags on the tubesheet</li> </ul> | <ul style="list-style-type: none"> <li>• Lower pressure drop (lower operating cost)</li> <li>• Prevents bag from falling through the tubesheet hole during installation</li> <li>• Reduces wear at the bottom of the bags due to bag swag (lower maintenance costs)</li> <li>• Easier, faster installation of bags and cost savings on replacement bags</li> <li>• Faster installation without loss of hardware</li> </ul> |
| <p><b>Boltsafe™ Hardware on standard cage:</b></p> <ul style="list-style-type: none"> <li>• Threadless tip</li> <li>• Retaining clip keeps bolt attached to the cage cover</li> <li>• Tapered tip centers bolt automatically</li> <li>• Secure connection between the cage and tubesheet improves grounding</li> </ul>  | <ul style="list-style-type: none"> <li>• Threads cannot become filled with dust</li> <li>• Bolts cannot fall out of the cage cover and drop into the collector</li> <li>• Cage is firmly grounded to the tubesheet</li> </ul>   | <ul style="list-style-type: none"> <li>• Prevents stripped threads and sheared off bolt heads</li> <li>• Bolts are easier to remove, saving time and reducing aggravation</li> <li>• Easier to find the bolt hole, saving time</li> <li>• Static charge dissipated, significantly reducing the chance of explosions caused by static buildup</li> </ul>  |

| Features   | Advantages  | Benefits   |
|--|---|--|
| <p><b>Unique bag cleaning principle:</b></p> <ul style="list-style-type: none"> <li>• Two (2) pulse nozzles direct the compressed air into each bag</li> </ul>   | <ul style="list-style-type: none"> <li>• Nozzles minimize losses present in conventional pulse-jet system, making more energy available for bag cleaning at no added cost</li> </ul>    | <ul style="list-style-type: none"> <li>• Allows unit to operate at high air-to-media ratios</li> </ul>   |
| <p><b>Ease of installation and maintenance:</b></p> <ul style="list-style-type: none"> <li>• Higher air-to-media ratio makes unit physically smaller than conventional pulse-jet collectors</li> <li>• Bags are designed for installation and removal from the clean air side using a “walk-in” or “walk-on” design</li> <li>• “Walk-in” design encloses solenoids and diaphragm valves</li> </ul> | <ul style="list-style-type: none"> <li>• Smaller unit is easier to install</li> <li>• Smaller unit has proportionately fewer parts to maintain (bags, diaphragms, solenoids)</li> </ul> | <ul style="list-style-type: none"> <li>• Conserves space</li> <li>• Fewer installation costs</li> <li>• Lower maintenance costs</li> <li>• Limited exposure of maintenance personnel to dust</li> <li>• Maintenance personnel protected from environment during maintenance and bag changes</li> </ul> |