

Benches - Downdraft, Welding and Remote

Donaldson® Torit® has offered Downdraft Benches since the 1960s to provide a downdraft work surface combined with a highly efficient dust collection system. The Donaldson Torit Downdraft Bench (DB-2000 and DB-3000) introduced in 2000, provides continuous-duty cleaning by means of high-efficiency Fibra-Web® cartridge filters.

Donaldson Torit Downdraft Bench - Product Overview

The Donaldson Torit Downdraft Bench combines a ruggedly-constructed work surface with the high-efficiency Fibra-Web FR (Flame-Retardant) filter cartridge. The Donaldson Torit Downdraft Bench houses multiple cartridges, a clean plenum with integral motor/blower assembly and pulse-jet cleaning system, and dust drawers. This provides for a highly efficient self-cleaning filtration system ensuring long filter life and reduced maintenance expenses. The units are designed for easy filter changeout through the access door(s) on one end of the unit.

The Donaldson Torit Downdraft Bench units, DB-2000 and DB-3000, are available unwired or fully wired with nominal airflow ratings of 2,000 cfm and 3,000 cfm (3,398 and 5,097 m³/h), respectively. Direct drive, airfoil fans provide a 200 fpm (1.02 m/s) minimum face velocity across the slotted-steel work surface. The top of the unit has hinged side panels that can open to fit longer workpieces. An integral fluorescent light illuminates the work area providing a well-lit surface for workers. The bench top maximum load capacity is 75 lb/ft² (366 kg/m²).

The Remote Downdraft Bench units, RDB-2000 and RDB-3000, provide a work surface and dust capture point to be ducted to a separate collector.

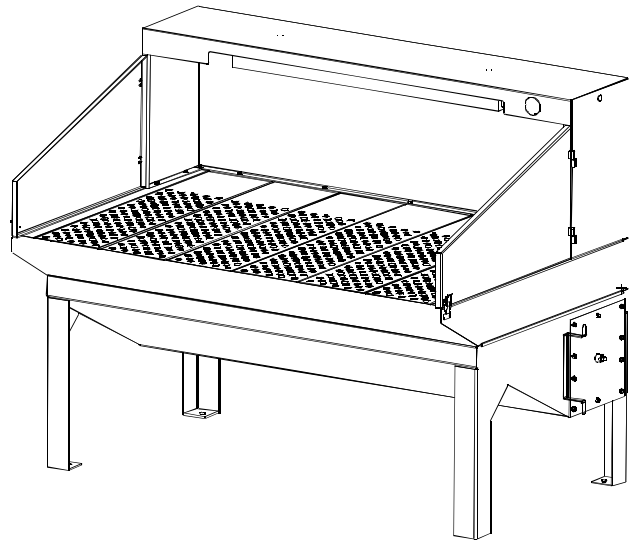
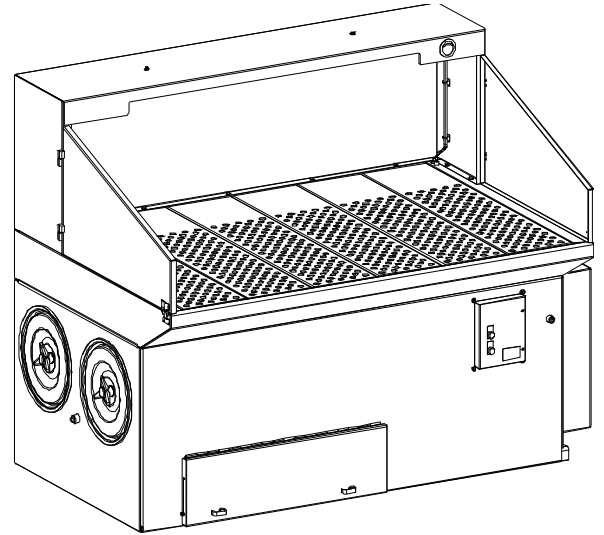

Operation Explanation

Normal Operation: Dust-laden air is drawn over the workpiece, through the grating, and into the DB collector. An inlet baffle diverts the air and prevents contaminants from impinging directly onto the cartridge. Heavy particulate falls into the dust drawer(s), and fine particulate is collected on the outside surface of the filter elements. Air then passes through the cartridges and into the clean air plenum. Clean air exhausts out the side of the collector through the silencing chamber. As the dust cake collects on the outside filter surface, pulse-jet cleaning and gravity force the dust from the filters to drop into the dust tray.

Filter Cleaning: Filter elements are arranged in two rows, one filter deep using ¾" diaphragm valves, or two filters deep using 1" diaphragm valves. The inner filter, opposite the access cover, opens into a clean air plenum which houses cleaning valves and manifold.

Solenoid-operated diaphragm valves open in sequence, introducing momentary jets of high-pressure air to the filter element cartridges. The resulting pulse dislodges the dust accumulated on the outside of the filter media. The remaining filter elements in the unit continue the filtration process.

Using the optional prewired controls, the filter elements are cleaned automatically at the end of each shift. The unit is powered down when the off pushbutton is depressed. 3 seconds later, the first valve fires, followed by the second valve ten seconds later. The fan then restarts 3 seconds after the second valve fires. After 60 seconds the fan shuts off. This sequence repeats three times, providing safe and thorough filter cleaning. This minimizes worker exposure to pulse-cleaning noise.

Unwired models may be pulsed aftershift with a delay timer (by others) or cleaned continuously.

Application Summary

Donaldson Torit Downdraft Benches provide excellent efficiency on nuisance dust generated in industrial operations, such as steel grinding, buffing and polishing operations without rouges, and hand-sanding operations.

Steel Grinding: DB units are particularly well-suited for steel or other ferrous metal grinding operations. The units have a baffle that limits sparks from impinging directly with the Flame-Retardant Fibra-Web cartridges. Because the filter media will not support combustion, the risk of fire is reduced.

Buffing and Polishing Operations without Rouges: The units can also be used for some buffing or polishing operations. (Fibra-Web filter cartridges are well-suited for this application since they do not have outer liners.)

Hand-Sanding Operations: DB units can be used for hand-sanding operations. The application should be light-duty.

Applications to avoid include those with explosive dusts and welding operations.

Explosive Dusts: The DB units are **not** to be used on explosive dusts as they do not have an explosion-proof design.

Welding Operations: Many people like to use Downdraft Benches for welding operations. This is not recommended because weld fumes want to rise, and Downdraft Benches develop a downward airflow. The natural tendency of the contaminant is directly opposite to the direction of the airflow created by the collector. This makes it extremely difficult to capture the weld fume. If the contaminant cannot be captured, it cannot be filtered.

Donaldson Torit also offers the Weld Bench models WB-2000 and WB-3000 (see p.6). These units provide a back-draft hood and Ultra-Web® II FR filter cartridges - making it the perfect

choice for welding small and medium parts. Remote Welding Bench models RWB-2000 and RWB-3000 (see p.6) are also available.

Remote Installation: The remote benches offer a work surface and contaminant capture suitable for connection to a separate collector. This is especially beneficial when handling combustible materials where collectors may need to be located outside, but the work needs to be performed inside. Another benefit is that a single filter section can be used with multiple benches. Remote Downdraft Benches are also suitable for buffing, grinding, and polishing operations when ducted to an appropriate dust collector.

Sizing and Selecting Criteria

Each DB is designed to provide 200 fpm (1.02 m/s) minimum face velocity across the perforated steel work surface. The DB-2000 includes a 3 hp direct drive fan providing 2,000 cfm (3,398 m³/h), while the DB-3000 includes a 5 hp fan pulling 3,000 cfm (5,097 m³/h).

Features and Benefits

| Features | Benefits |
|---|---|
| Fibra-Web Flame-Retardant cartridges | <ul style="list-style-type: none"> • Highest filtration efficiency, superior filter life, and flame-retardant properties on fine fibrous particulate |
| Automatic self-cleaning pulse-jet system | <ul style="list-style-type: none"> • Continuous or aftershift cartridge cleaning options |
| Access doors on one end of unit | <ul style="list-style-type: none"> • Easy filter changeout |
| Large capacity dust drawers | <ul style="list-style-type: none"> • Less frequent maintenance |
| Integral fluorescent light | <ul style="list-style-type: none"> • Illuminated work area that makes it easier for workers to see what they are doing |
| Hinged side panels | <ul style="list-style-type: none"> • Flexibility for larger than normal workpieces |
| Quiet operation and ergonomic design | <ul style="list-style-type: none"> • Increased worker productivity and morale |
| Prewired controls (recommended option) | <ul style="list-style-type: none"> • Reduced installation expenses and minimized exposure to pulse-cleaning noise |

Downdraft Bench Model DB-800 - Product Overview

The Donaldson Torit® Downdraft Bench DB-800 combines a work surface with a high-efficiency, intermittent-duty cleaning dust collection system, utilizing envelope-style filters in Donaldson's EZ Filter Pack™. Designed in 2000, the DB-800 is self-contained and includes the envelope filters, blower, shaker system, perforated work surface, dust drawer for easy emptying, and rugged steel body. The direct drive fan delivers 200 fpm (1.02 m/s) capture velocity for effective dust control. A three-sided enclosure and hinged side panels are standard. Also available are three EZ Filter Pack™ choices, casters, and prewired controls.

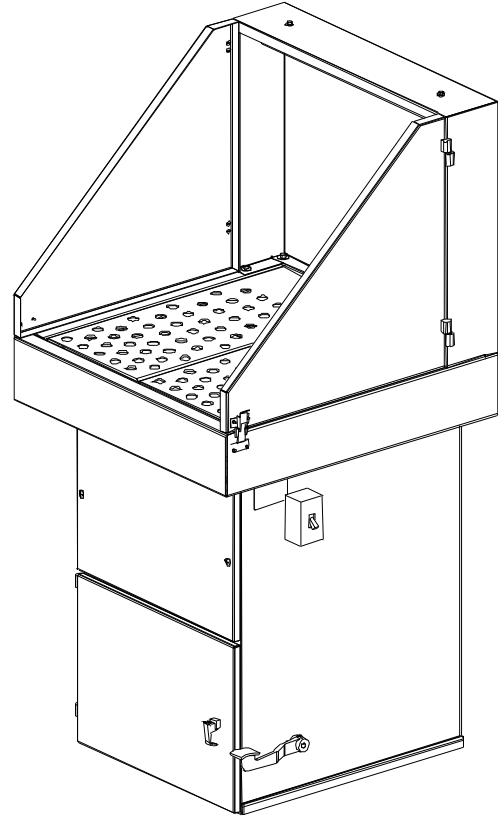

Operation Explanation

Normal Operation: Airflow from the unit pulls the dust down through the work surface. Air velocity is consistent across the entire work surface. Large particles are collected in the dust drawers while fine particulate is captured on the surface of the filter media, building a dust cake, and increasing filtration efficiency. Clean air flows through the center of the envelope filters into the blower, and exits out of the top clean air outlet.

Filter Cleaning: The fan motor must be turned off before filter cleaning. The manual shaker pedal is pushed and lifts the bottom of the filter bag. The lifting, flexing, and dropping actions dislodge the dust from the filter. The dust then falls into the dust drawer. The optional autoshake feature includes a motor to remove the dust after the unit is turned off.

Application Summary

The Donaldson Torit DB-800 provides excellent efficiency on nuisance dust generated in industrial operations, and is a good choice for light-loading applications that do not require continuous airflow. Typical applications include polishing, sanding, grinding, and other hand operations. As with most fabric filter systems, applications that produce wet, oily, or sticky contaminants should be avoided. Explosive dusts and welding operations should also be avoided.

Sizing and Selecting Criteria

The DB-800 contains cotton sateen filter media and a 1.5 hp motor, providing 700 cfm (1,189 m³/h) across a perforated steel work surface with new envelope filters. As with all intermittent-duty collectors, the nominal cfm ratings of the DB-800 fan are based on airflow with clean filters. These ratings need to be corrected for typical operating conditions. To allow for the loss of airflow as the dust cake develops, assume airflows of 80 percent of the airflow achieved with new filters.

Remember that all intermittent-duty collectors require shutdown of the unit for cleaning. The airflow through the filter must be stopped before shaking the filter to avoid dust migrating through the woven fabric during cleaning. The cleaning frequency will depend on the application.

Features and Benefits

| Features | Benefits |
|---|--|
| Intermittent-duty operation with mechanical cleaning | <ul style="list-style-type: none">• No compressed air required |
| Durable perforated work surface | <ul style="list-style-type: none">• Maximum loading 50 lb/ft² (244 kg/m²) |
| 1.5 hp fan pack | <ul style="list-style-type: none">• High downdraft velocity through the entire work surface - 200 fpm (1.02 m/s) |
| Direct drive fan and baffled airflow | <ul style="list-style-type: none">• Quiet, consistent capture performance |

Donaldson Torit® Weld Bench - Product Overview

The Donaldson Torit Weld Bench combines a robust, #7 gauge grounded work surface with the high-efficiency Ultra-Web® II FR (Flame-Retardant) filter cartridge. The Donaldson Torit Weld Bench houses multiple cartridges, a clean plenum with integral motor/blower assembly and pulse-jet cleaning system, and dust drawers. This provides for a highly efficient self-cleaning filtration system ensuring long filter life and reduced maintenance expenses. The units are designed for easy filter changeout through the access doors on one end of the unit.

The Donaldson Torit Weld Bench units, WB-2000 and WB-3000, are available unwired or fully wired with nominal airflow ratings of 2,000 cfm and 3,000 cfm (3,398 and 5,097 m³/h), respectively. Direct drive airfoil fans provide 150 fpm (0.762 m/s) capture velocity through the welder's breathing, ensuring a clean, safe, and productive working environment. The top of the unit has hinged side panels that can open to fit longer workpieces. An integral fluorescent light illuminates the work area providing a well-lit surface for workers. The bench top maximum load capacity is 150 lb/ft² (762 kg/m²).

The Remote Weld Bench units, RWB-2000 and RWB-3000, provide an illuminated work surface for capture of welding fume to be ducted to a separate cartridge collector.

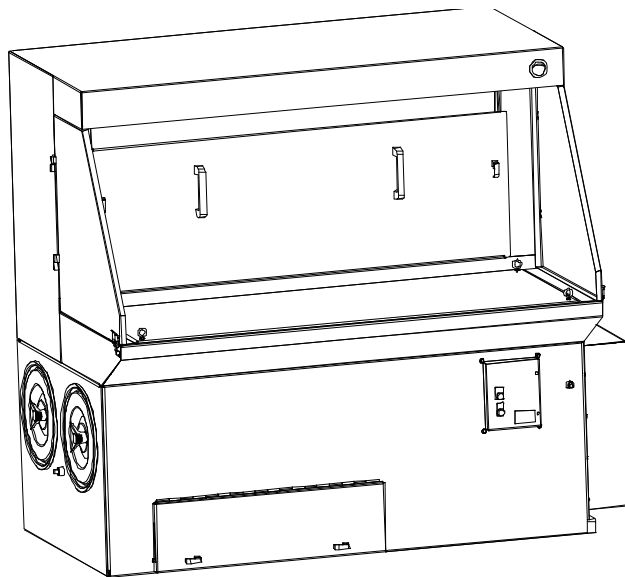

Operation Explanation

Normal Operation: Fume-laden air is drawn through the breathing zone, over the workpiece, and into the backdraft hood. An inlet baffle diverts the air and prevents contaminant from impinging directly onto the cartridge. Heavy particulate falls into the dust drawer(s), and fume is collected on the outside surface of the filter elements. Air then passes through the cartridges and into the clean air plenum. Clean air exhausts out the side of the collector through the silencing chamber. As the fume builds on the surface of the filter media, pulse-jet cleaning and gravity force the dust from the filters to drop into the dust tray.

Filter Cleaning: Filter elements are arranged in two rows, one filter deep (using ¾" diaphragm valves) or two filters deep (using 1" diaphragm valves). The inner filter (opposite the access cover) opens into a clean-air plenum which houses cleaning valves and manifold.

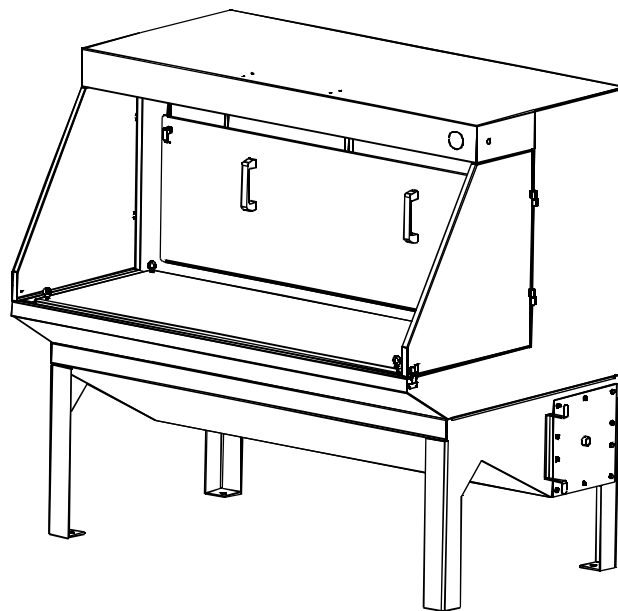

Solenoid-operated diaphragm valves open in sequence, introducing momentary jets of high-pressure air to the filter element cartridges. The resulting pulse dislodges the dust accumulated on the outside of the filter media. The remaining filter elements in the unit continue the filtration process.

Using the optional prewired controls, the filter elements are cleaned automatically at the end of each shift. The unit is powered down when the off pushbutton is depressed. 3 seconds later, the first valve fires, followed by the second valve ten seconds later. The fan then restarts 3 seconds after the second valve fires. After 60 seconds the fan shuts off. This sequence repeats three times, providing safe and thorough filter cleaning. This minimizes worker exposure to pulse-cleaning noise.

Unwired models may be pulsed aftershift with a delay timer (by others) or cleaned continuously.

Application Summary

Trunkline[®] Weld Benches provide excellent capture of weld fume on small parts eliminating the need for extraction arms for improved fume capture and increased productivity.

Welding Operations: Many people like to use Downdraft Benches for welding operations. This is not recommended because weld fumes want to rise, and Downdraft Benches develop a downward airflow. The natural tendency of the contaminant is directly opposite to the direction of the airflow created by the collector. This makes it extremely difficult to capture the weld fume. If the contaminant can not be captured, it can not be filtered.

The Weld Bench models' back-draft hood and Ultra-Web II FR filter cartridges make them the perfect choice for welding.

Explosive Dusts: The WB units are **not** to be used on explosive dusts, as they do not have an explosion-proof design. The RWB ducted to a properly sized dust collector with appropriate explosion-protected features would be recommended for explosive dusts.

Sizing and Selecting Criteria

Each Weld Bench is designed to provide 150 fpm (0.762 m/s) minimum-capture velocity through the breathing zone. The WB-2000 includes a 3 hp direct drive fan providing 2,000 cfm (3,398 m³/h), while the WB-3000 includes a 5 hp fan pulling 3,000 cfm (5,097 m³/h).

Features and Benefits

| Features | Benefits |
|---|--|
| Ultra-Web II Flame-Retardant cartridges | <ul style="list-style-type: none"> • Highest filtration efficiency, superior filter life, and flame-retardant properties on fine fume |
| 150 fpm capture velocity | <ul style="list-style-type: none"> • Provides a clean, safe, and productive working environment |
| Automatic self-cleaning pulse-jet system | <ul style="list-style-type: none"> • Continuous or aftershift cartridge cleaning options |
| Access doors on one end of unit | <ul style="list-style-type: none"> • Easy filter changeout |
| Large capacity dust drawers | <ul style="list-style-type: none"> • Less frequent maintenance |
| Integral fluorescent light | <ul style="list-style-type: none"> • Illuminated work area that makes it easier for workers to see what they are doing |
| Hinged side panels | <ul style="list-style-type: none"> • Flexibility for larger-than-normal workpieces |
| Quiet operation and ergonomic design | <ul style="list-style-type: none"> • Increased worker productivity and morale |
| Heavy-Duty work surface | <ul style="list-style-type: none"> • Handles heavy parts (to 150 lbs/ft²) and holds up under the welding environment |
| Prewired controls | <ul style="list-style-type: none"> • Reduced installation costs, reduces worker exposure to pulse-cleaning noise |