

Remote Downdraft Bench

Models RDB-2000 and RDB-3000

Designed for buffing, polishing, and grinding operations, the remote workstation integrates easily with other Donaldson® Torit® air filtration products.



RDB-3000

- Rugged construction.
- Heavy-duty work surface, 12-gauge galvanized channels with 7/8" holes.
- Hinged side-wing panels open to accommodate longer workpieces.
- Built-in fluorescent light illuminates work area.
- Larger model and longer worktable suits two workers.
- Ergonomically designed for operator comfort.
- Helps support OSHA Clean Air Standards.
- Productivity increases and morale improves by providing a cleaner working environment.
- 10-year warranty.

Remote Downdraft Bench

Dimensions & Specifications

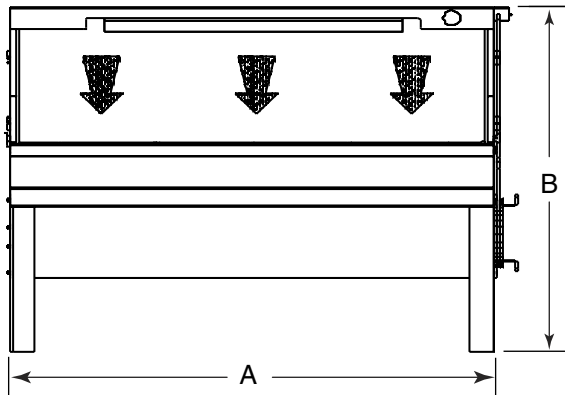

Front View

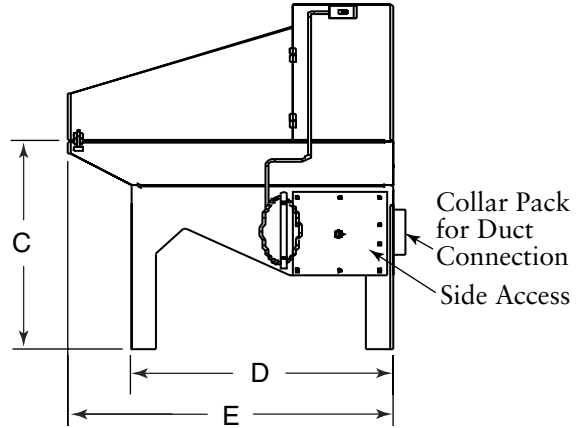

Right Side View

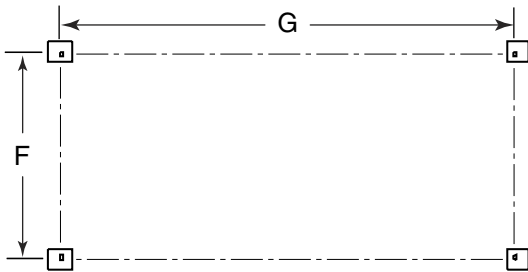

Bottom View

Model	Outlet Diameter (inches)	Dimensions (inches)							Max Load per Sq. Ft. (lbs)	Shipping Weight (lbs)
		A	B	C	D	E	F	G		
RDB-2000	8, 10, 12	52.0	63.0	38.0	42.1	52.0	37.1	47.0	75	411
RDB-3000	10, 12	78.0	63.0	38.0	42.1	52.0	37.1	73.0	75	550

Equipment Options

- Scratch-resistant work surfaces.
- Easy Duct™ quick clamp ductwork for easy do-it-yourself installations.



Donaldson Company, Inc.
 Industrial Air Filtration
 P.O. Box 1299
 Minneapolis, MN 55440
 Tel 800-365-1331(USA)
 Tel 800-343-3639 (within Mexico)
 donaldsonorit@donaldson.com
 www.donaldsonorit.com

Significantly improve the performance of your collector with genuine Donaldson Torit replacement filters and parts.

Browse our catalog at www.donaldsonorit.com



Information in this document is subject to change without notice.

© 2001 Donaldson Co., Inc.
 Printed in U.S.A. on recycled paper

Data Sheet RDB (01/08)