

Product Overview - Modular MediaFilter™ II (MD and MDV)

In 1995 designs were started for a new generation of Modular MediaFilter™ units specifically designed for wet applications. Although heavy emphasis was placed on wet applications, modules and options for sticky dusts and other contaminants were also requested.

In 1996 the Modular MediaFilter™ II systems were released. New leak resistant designs and advance filter sealing concepts were investigated, tested and proven.

Designed primarily for wet applications, the Modular MediaFilter II units feature the following design features to improve cabinet sealing and system maintenance in wet applications.

Vertical mounting - Designed primarily for wet applications, units are configured for vertical mounting (not available for horizontal mounting). Vertical mounting improves filter drainage and helps wash solids out of the filters improving filter life.

Panned plenum design - Inlet plenum mounting flange is panned and the filter module is set inside. This eliminates potential leak points through fasteners or insufficiently caulked mounting flanges.

Trepanned plenum - Sloped bottom provides better drainage and helps wash solids out of the plenum.

Larger, lower velocity plenum - The slightly larger size of the inlet plenum reduces inlet velocity allowing more droplets to fall out of the air stream reducing loading and maintenance on the filters.

Full-size filter access door - The full size filter access door provides easy access to filters for replacement without the need to climb into the cabinet (considered by OSHA as a confined space). Door is mounted on removable pin hinges and can be removed or easily replaced if required. Large, easy to use “T” handle latches are used for quick access to filters.

Pin hinged blower access door - A pin hinged access door is provided on the blower/motor cabinet. A hinged panel makes is both safer and easier for maintenance (prevents damage or injury from falling removable panels).

Drain gutter on door - On wet applications, liquids can accumulate on the cabinet doors and drip on the floor or surfaces below when the doors are opened for filter service. Doors are

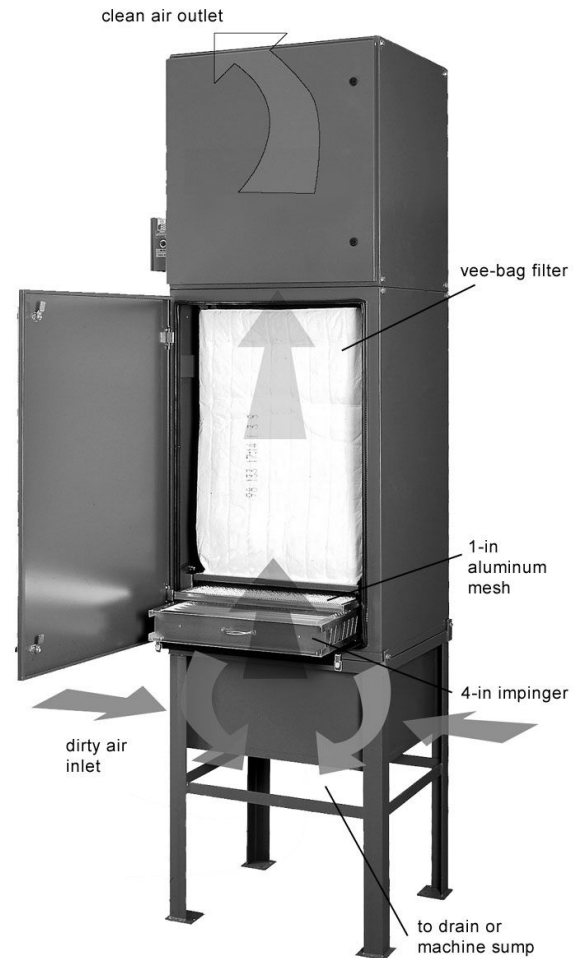

provided with a catch gutter on the bottom of the door to prevent coolant drainage off the door during filter service.

Filters set into the cabinet - Filters are recessed into the cabinet and off of the door and internal surfaces. This allows for better utilization of the filter media, acts as a drop out for any droplets, and keeps fluids off the access door surfaces.

Vee-bag sealing frame – Improved, final stage vee-bag filter sealing gasket is provided with the removable and/or replaceable sealing frame. Face sealing of the filter eliminates filter leakage and bypass problems found with conventional side-mounted gasket sealing that result from air gaps caused by variations in the filter frame dimensions. The frame is designed to allow for easy replacement if seals are damaged or worn.

Improved bag hangers – Allows bags to be installed and hung from outside of the cabinet. Locking tabs are provided to prevent filter bunching and maintain even filter spacing for full utilization of filter media and optimum filter life.

Custom direct drive blowers – MediaFilter II units are available with custom, direct drive blowers designed to meet specific system airflow and pressure requirements should the standard blower performance be insufficient.

Operational Explanation

MDV System (Vertical Mounting): The MDV system is typically utilized in source capture applications for the removal of wet contaminants (mists) with secondary contaminants of light to heavy dusts (wet grinding, grinding swarf) and light smoke or fume. Heavier concentrations of smoke and fumes may require the addition of a HEPA filter (MH) module. This unit mounts in the vertical position to enhance filter drainage and improve Vee bag filter life, as dirt is washed out of the Vee bag in vertical mounted units.

In operation, contaminant-laden air is drawn into the flex hose or duct system and carried to the inlet plenum of the MediaFilter collector. Larger, heavier contaminants such as droplets drop out of the air stream due to the reduction in air velocity. The mist laden air enters the first stage chevron type Impinger which coalesces a large percentage of the mist into droplets for drainage back into the inlet plenum. The air then passes through a cleanable aluminum mesh filter prior to entering the ten (10) pocket Vee bag (rated 95% efficient by ASHRAE 52-2) where sub-micronic mist particles are trapped and retained within the filter media. The Vee bag filters are constructed of industrial grade media with the highest loft (thickness) and finest fibers available for superior efficiency and dirt holding capacity. As the filter starts to saturate with liquids, gravity drainage of the coalesced liquids occurs as the clean air is returned to plant environment.

Application Summary

Primarily designed for wet applications the MediaFilter™ II have filter interchangeability for sticky dusts and other complex contaminants. Filter module and filter options are as follows:

Prefiltration Modules

MI - Impinger module, housing with cleanable 4" Impinger and 1" Aluminum mesh filter. An optional, add on Z track allows for the addition of a third stage 4" Impinger, Multi-vee or Metal Mesh filter stage. Typically used for applications either high mist loading and /or heavy amounts of chips and swarf.

MM – Multi-vee module, housing with 1" disposable prefilter and 4" disposable Multi-vee filter. An optional, add on Z track allows for the addition of a third stage 4" Impinger, Multi-vee or Metal Mesh filter stage.

Primary Filter Modules

MD - Module containing three disposable filter stages: (1st) 1" Prefilter; (2nd) 4" Multi-vee filter; and (3rd) 95% Vee bag. Typically used for “dry” applications.

MDV - Module containing three stages of filtration: (1st) 4" Impinger; (2nd) 1" Aluminum mesh filter; and (3rd) 95% Vee bag. First two filters are cleanable while the third-stage Vee bag is disposable. Typically used as the primary filter module for mist applications.

Primary or Secondary Filter Modules

MH - HEPA module, housing a disposable high efficiency particulate air or absolute filter rated 99.97% efficient at 0.3 microns. The 95% DOP filter may be used in this housing instead of a HEPA. Typically used when smoke and/or thermally generated mist is present or customer requires highest filtration efficiency available.

MC1 - Carbon module used in “low” concentration gas or odor applications. Module contains a removable, refillable, filter-fold filter containing 45 lbs of activated carbon followed by a 1" pleated post filter. Alternate media such as reactive carbons, potassium permanganate, activated alumina and zeolite are available. Use for nuisance type vapor/gas phase odors.

MB - Blower module consisting of standard single (MDV-3000) or dual (MDV 6000/9000) fan, belt drive blower; motor; drive belt; fixed sheave on the blower; adjustable sheave on the motor to allow variation of airflow or static pressure; outlet diffuser grill; and NEMA 4 junction box. MediaFilter II units are available with custom, direct drive blowers designed to meet specific system airflow and pressure requirements should the standard blower performance be insufficient.

The MDV units can collect solids particles such as grinding swarf (dust suspended in coolant) along with the mist; however, it should typically not be operated without mist. There should be some type of liquid material present to allow coalescing and filter drainage, which will help remove collected solids and increase filter life. The extremes of very heavy oils and very light, thin oils will require adjustment of air to media ratios for proper performance. The very heavy oils (similar to tar consistency) will not drain requiring higher-pressure blowers and conservative filter sizing. The very light, thin oils (similar to gasoline consistency) may evaporate while water soluble coolants may evaporate, thicken and gel requiring additional prefilter stages, conservative sizing, and high performance blowers.

MD Source Capture Applications: MD series MediaFilter units are suitable for collecting sticky, oily or adhesive dusts that cannot be collected well with other systems. They are not intended

for collection of dry dusts that cleanable filter systems are capable of handling. In applying MD units on sticky, oily, or adhesive dust applications, filter replacement costs versus dirt loading must be considered as MD units are more suitable for lighter dirt loadings. Wet dust collection systems may be a more cost effective control approach for heavier wet dirt loading.

The general guidelines that are key for applying MD and MDV Modular MediaFilter collectors are provided as follows.

Air-to-Media Ratio: The sizing and tailoring guide below works for most “typical” oil mist applications. Any time you have “out of the ordinary” variables call your Applications Engineer. High temperatures, high chuck rotation, high oil injection pressure, and dense smoke are issues they can help you overcome.

Remember to take the airflow capability of safety filters and carbon packs into consideration. You do not want to exceed the 2000-cfm airflow capacity of a HEPA filter.

The numbers in the guide below are for an MDV-3000 based on mist loading. Double the numbers for an MDV-6000 and triple them for an MDV-9000. Light loading is 0 – 5 mg/m³, medium loading is 6 – 25 mg/m³, and heavy loading is >25 mg/m³.

Duty Cycle	Light	Medium	Heavy
Up to 16 hours/day	2500 CFM	2000 CFM	1500 CFM
16 to 20 hours/day	2000 CFM	1500 CFM	1200 CFM
24/7	1200 CFM	1000 CFM	800 CFM

HEPA or 95% DOP Option: Smoke, and sub-micron particles generated from heat build up is quite common in applications where straight oils and water-soluble coolants are used. In applications where heavier amounts of smoke or thermally generated particles are generated, the HEPA filter module or the 95% DOP filter module option is recommended. The 95% DOP filter has a higher capacity, but is not as efficient as the HEPA filter.

Carbon Option: Burning coolants can create odors and solvent-based straight oils can generate vapors that require collection. Two optional Carbon modules are available for removal of nuisance gas/vapor and odorous contaminants. Alternate medias are also available. Some odors are particles instead of vapors, in which case use a HEPA filter. Contact Applications Engineering for proper sizing of the Carbon module.

Sizing and Selecting Criteria

The most important key to successful sizing of MediaFilter units is based on using conservative ratings on units. Mechanical filter systems lose airflow as dirt buildup on the filters so larger systems are suggested for dirtier applications. Undersized units lose airflow rapidly as smaller filters load with gelled coolants or solid particles requiring more frequent filter replacement and higher long term operating costs. Over sizing units results in longer filter life, lower maintenance and greater long term savings. Experience indicates that doubling the unit size will typically result in three to four times the filter life and huge long term savings compared to the short term, additional cost of the larger collector.

See the Wet Machining application paper online at DTIC (Donaldson Torit Information Center) for more information about calculating the required airflow.

Features and Benefits

Features	Benefits
Vertical mounting	<ul style="list-style-type: none"> • Improved filter life through enhanced filter drainage and solids removal out of the filters
Panned plenum design	<ul style="list-style-type: none"> • Eliminates potential leak points through fasteners
Trepanned plenum	<ul style="list-style-type: none"> • Better drainage out of the inlet plenum helps prevent re-entrainment of collected mist.
Larger, lower velocity plenum	<ul style="list-style-type: none"> • Reduced inlet velocity allows more droplets to fall out of the airstream reducing loading and filter maintenance
Full-size filter access door	<ul style="list-style-type: none"> • Easy access to filters • Door is removable if needed • “T” handle latches provide quick filter access
Hinged blower access door	<ul style="list-style-type: none"> • Safer and easier maintenance
Drain gutter on door	<ul style="list-style-type: none"> • Prevents coolant drainage off the door during filter service
Filters set into the cabinet	<ul style="list-style-type: none"> • Better utilization of filter media • Acts as drop out box for any droplets • Keeps fluids off the access door surfaces
Sealed blower outlet	<ul style="list-style-type: none"> • Prevents air leakage into the blower cabinet • Improves blower efficiency • Higher performance at the collector inlet
Vee-bag sealing frame	<ul style="list-style-type: none"> • Eliminates filter leakage and bypass • Easy replacement if seals are damaged or worn
Improved bag hangers	<ul style="list-style-type: none"> • Bags installed from outside the cabinet • Locking tabs prevent filter bunching and maintain even filter spacing • Full utilization of filter media and optimum filter life
Custom direct drive blowers	<ul style="list-style-type: none"> • Meet specific system airflow and pressure requirements